

F120 Room Air Cleaning System

PRODUCT DATA

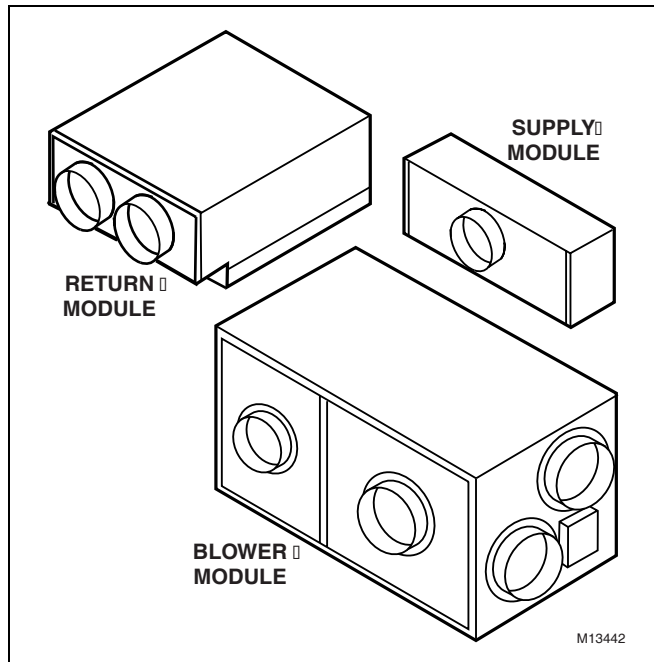

FEATURES

- Specifically designed for use in offices, hospitals, medical clinics, childcare centers, schools, conference rooms, copy centers, laboratories, cafeterias, and hospitality business.
- Ultra-quiet operation allows the system to be used in sound sensitive areas such as conference rooms, offices, classrooms and libraries.
- Modular design of air supply and return allows maximum flexibility when planning the appropriate air recirculation pattern to maximize overall system performance.
- Special return module filter removes both particulates and gaseous contaminants from the air stream.
- Convenient roomside service for all filters.
- Easy-to-change prefilter extends the media filter life.
- Blower module can be mounted remotely from the room to further reduce sound levels.
- Two-speed fan motor allows selecting high or low airflow speeds.
- Optional exhaust feature allows installations to maintain the space at a negative pressure with respect to surrounding areas to prevent contaminants and odors from moving into nearby areas.
- Installation is ideally suited to rooms with either two-by-four or two-by-two foot drop ceiling panels, but can be installed in any wall or ceiling that allows ducting space.

• READ AND SAVE THESE INSTRUCTIONS

GENERAL

The F120 Room Air Cleaning System is designed to collect particles by circulating room air through a media filter. When equipped with an optional CPZ module, the system also adsorbs gaseous contaminants and odors.

The F120 exhaust feature is used to maintain the space at a negative pressurization relative to adjacent spaces to prevent contaminants and odors from moving into nearby areas.

The air supply and return design of the F120 allows air contaminants to be filtered at the center of the room with the filtered air returned toward the sides of the room for maximum room air cleaning.

Contents

General.....	1
Features	1
Specifications	2
Ordering Information	2
Planning the Installation	3
Installation	7
Operation.....	11
Maintenance.....	11
Parts List	11
Warranty	16

SPECIFICATIONS

IMPORTANT

The specifications given in this publication do not include normal manufacturing tolerances. Therefore, this unit may not exactly match the listed specifications. This product is tested and calibrated under closely controlled conditions, and some minor differences in performance can be expected if those conditions are changed.

Model:

F120 consists of:

- two filtered return modules with a return grille, prefilter, and
- either a 99.97% HEPA filter or a 95% DOP filter and CPZ module;
- four air supply modules with supply grilles;
- a blower module with a two-speed blower, four recirculating air supply openings, four recirculating air return openings and an optional exhaust opening.

- mounting hardware kit consisting of 12 mounting brackets; 40 ft (12m) of 12-gauge high-tensile strength wire; six standard T- bar mounts; duct tape;
- seven duct collar straps.

Color:

Blower Housing: Unpainted galvanized steel.
Return and Supply Grilles: Off-white

Electrical Ratings:

	120 Vac, 60 Hz		240 Vac, 60 Hz	
	Fan Speed ^a		Fan Speed ^a	
	II (high)	I (low)	II (high)	I (low)
Current (A)	7.0	5.5	3.5	2.8
Power (W)	800	695	800	695

^aOff is "O".

Air Flow Capacity:

Model	Voltage	Efficiency		Gas, VOC, Odor Control Module (2)	Air Vol cfm (cu m/hr)	Air Vol cfm (cu m/hr) ^a
		Particulates at 0.3 micron (DOP Test)	VOC/Odors (First Pass Average)			
F120A 1023	120 Vac 60 Hz	95%	85%	CPZ	900 (1530)	1050 (1780)
F120A 1031	120 Vac 60 Hz	99.97%	—	—	900 (1530)	1000 (1700)
F120A 1015	120 Vac 60 Hz	b	b	b	—	—

^a With exhaust option installed.

^b Purchase filters separately.

Filters:

HEPA: High efficiency particulate air (HEPA) filter is 99.97 percent efficient for 0.3 micron particulates when measured with Military Standard 282 DOP test.

DOP: Hospital-grade DOP filter is 95 percent efficient for 0.3 micron particulates when measured with Military Standard 282 DOP test.

CPZ: Sorbent modules contain 11 pounds of sorbent. Adsorbs higher molecular weight hydrocarbons and oxidizes acid gases and lower molecular weight hydrocarbons.

Ambient Temperature Rating:

Shipping and Storage: -20°F to +150°F (-29°C to +66°C).
Operating: Ambient temperatures ≥90°F (32°C).
Can tolerate 104°F (40°C) for brief periods.

Sound Output Rating at 3.3 ft (1m):

High Speed: 52 dBA (below ASHRAE noise criteria (NC) curve specifications for NC45 over speech recognition frequency range of 500 to 2000 Hz).
Low Speed: 45 dBA (below ASHRAE noise criteria (NC) curve for NC35 over speech recognition frequency range of 500 to 2000 Hz).

ORDERING INFORMATION

If you have additional questions, need further information, or would like to comment on our products or services, please write or phone:

1. **Your local Honeywell Commercial Air Products Distributor.**

2. **Air-Pure Systems**
16873 Fish Point Rd. SE
Prior Lake, MN 55372-1714
Phone: (800) 998-1919
Fax: (800) 221-3248

Installation Weight:

Blower Module: 63 lb (28.6 kg).
 Supply Module: (4 required): 8 lb (3.6 kg).
 Return Module without filter (2 required): 24 lb (10.9 kg).
 95% DOP Filter/CPZ Module (2 required): 21 lb (9.5 kg).
 99.97% HEPA Filter (2 required): 10 lb (4.5 kg).

Shipping Weight:

F120 with 95% DOP Filter and CPZ Module: 207 lb (94 kg).
 F120 with 99.97% HEPA Filter: 182 lb (83 kg).
 F120A1015: 152 lb (69 kg).
 F120A1007: 70 lb (32 kg).

Dimensions:

See Fig. 1.

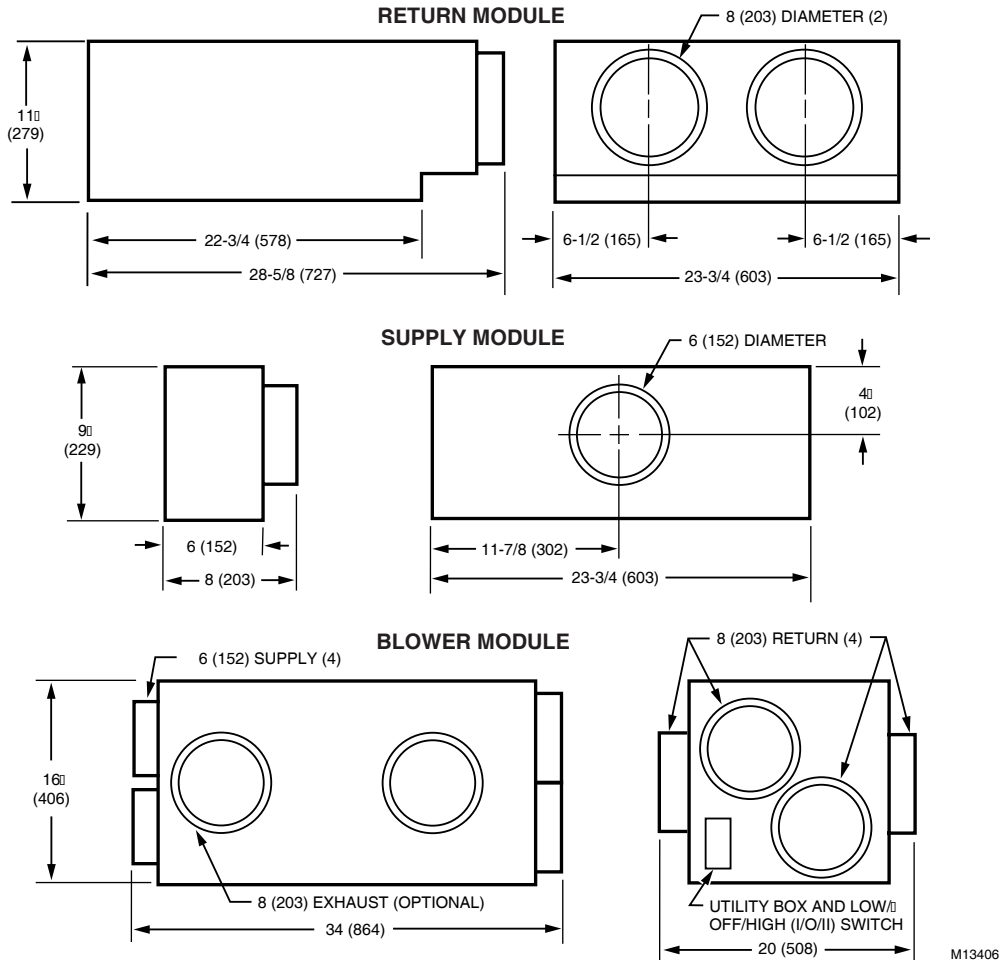

Fig. 1. Approximate F120 dimensions in in. (mm).

PLANNING THE INSTALLATION

The F120 Room Air Cleaning System is designed for use in offices, hospitals, medical clinics, childcare centers, schools, conference rooms, smoking rooms, copy centers, laboratories and cafeterias.

The quiet design allows the system to be used in sound sensitive areas such as conference rooms, offices, classrooms, and libraries where other air cleaning systems may be too noisy.

Determining F120 Size

Use the sizing procedure to determine how many F120 are needed. The correct number for a particular application depends on:

- type of contaminant.
 - number of occupants.
 - room volume.
 - room use.
 - outdoor air quality.
1. Select the fan speed to be used for the application as the normal operating speed. Select the speed according to the sound sensitivity level appropriate for the application (if the application requires an especially quiet operation, low speed sizing is recommended):
 - a. High speed – the sound output is below the ASHRAE NC-45 noise criteria curve over the speech frequency range of 500 to 2000 Hz.
 - b. Low speed – the sound output is below the ASHRAE NC-35 curve over the speech frequency range of 500 to 2000 Hz.

2. Determine if the room requires optional exhaust feature to prevent the migration of contaminants to other areas. (This F120 feature is used to maintain the controlled space at a slightly negative pressure.)

WARNING

Combustion Hazard.

Installing combustion appliances in same space as F120 System can cause backdrafting and hazardous gas accumulation.

Consult combustion appliance manufacturer installation instructions to determine appropriate installation location.

3. Identify the types of contaminants to be controlled. For particulates only, use the F120 with a 99.97% HEPA filter. To remove particulates and control odors and gaseous contaminants (for example, smoking rooms), use the F120 with a 95% DOP filter and a CPZ module.
4. Use the airflow ratings in the Specifications section to determine the number of F120 needed.
 - a. Size the air cleaning system using either air changes per hour (ac/h) or occupant load. See ASHRAE Standard 62-1999, Ventilation for Acceptable Indoor Air Quality, for the outdoor air requirements. (Use the clean recirculated F120 air for a portion of the recommended values.)
 - b. When calculating the system requirements, consider factors such as architectural features, lighting fixtures, sprinkler systems, HVAC air ducts, and grilles in the room.

Example 1: Sizing By Occupant Load

A cocktail lounge averages 75 occupants. How many F120 should be installed?

Solution:

$$\text{F120 required} = \frac{\text{ASHRAE clean air per person} \times \text{occupants}}{\text{F120 airflow capacity}}$$

ASHRAE recommends 30 cfm per person clean air for cocktail lounges. Operating the F120 on high speed with the exhaust feature and a 95% DOP filter, the airflow capacity is 1050 cfm. 80 percent of the air is supplied to the space and 20 percent is exhausted. (Air is drawn into the space from surrounding areas to compensate for the air removed.)

Calculation:

$$\begin{aligned} \text{Number of F120 required} &= \frac{30 \text{ cfm per person} \times 75 \text{ people}}{1050 \text{ cfm}} \\ &= \frac{2250 \text{ cfm}}{1050 \text{ cfm}} = 2 \text{ units} \end{aligned}$$

Minimal outside air is required.

Outside Air Calculation:

$$15 \text{ cfm per person} \times 75 \text{ people} = 1125 \text{ cfm.}$$

Example 2: Sizing By Air Changes Per Hour (Ac/h).

A restaurant measures 40 x 45 feet with a 12 foot ceiling. How many F120 should be installed?

Solution:

$$\text{F120 feet required} = \frac{\text{desired air circulation (cfm)}}{\text{F120 airflow capacity}}$$

Without considering other data, select the correct number of F120 units that provides between 8 and 12 ac/hr. This example uses 10 ac/hr. Operate the F120 on high speed with the exhaust feature and a 95 percent DOP filter; the airflow capacity is 1050 cfm.

Calculation:

First determine the volume of the space:

$$\text{Volume} = 40 \times 45 \times 12 = 21,600 \text{ cubic feet.}$$

Then determine the volume of air to be circulated.

$$21,600 \text{ cu ft} \times 10 \text{ ac/hr} = 216,000 \text{ cfh or}$$

$$\frac{216,000 \text{ cfh}}{60 \text{ min/hr}} = 3600 \text{ cfm}$$

$$\text{F120 required} = \frac{3600 \text{ cfm}}{1050 \text{ cfm}} = 3 \text{ units}$$

Minimal outside air is required.

Outside Air Calculation:

Provide air equal to 15 cfm/person.

Example 3: Designated Smoking Room

In buildings where smoking is banned in the general office area but segregated to an enclosed designated smoking room with its own ventilation system exhausted to the outside, what is needed?

Solution:

F120 with a 95 percent DOP filter, a CPZ module and the exhaust feature is the perfect solution for designated smoking rooms.

The F120 is specifically designed to maintain an acceptable comfort level for the occupants in rooms with up to fifteen smokers on High speed and up to twelve smokers on Low speed.

The exhaust feature exhausts up to 20 percent of the rated airflow of the F120 and maintains the smoking room at a negative pressure with respect to the surrounding areas.

Air exhausted from the room is treated by the 95 percent DOP filter and CPZ module; however, it must be exhausted from the building and not returned to the HVAC system

Provide minimal outside air. Supply fresh air to the room through a door grille or an outside duct.

Outside Air Calculation:

Allow 15 cfm per person.

Choosing the Location

The modular design of the F120 allows maximum flexibility to optimize the airflow pattern when selecting locations for the blower module, return modules, and supply modules.

1. Plan the position of the return and the supply modules so the airflow can reach the farthest area of the space:
 - a. Mount the return modules up to 20 ft (6m) and the supply modules up to 12 ft (3.5m) from the blower module (longer duct runs can be used with reduced airflow).

- b. Mount the return modules in the center of the area with two supply modules installed on each side. See Fig. 2.
- c. With multiple F120 in a room, distribute them equally throughout the space by dividing the entire space into equal volumes. See Fig. 3.
- d. To use the F120 to divide a large area into smoking and non-smoking sections, mount the return modules on one side of the smoking area and place the supply modules along the dividing line between the two sections. Use the exhaust option to help keep the smoke out of the non-smoking section. See Fig. 4.

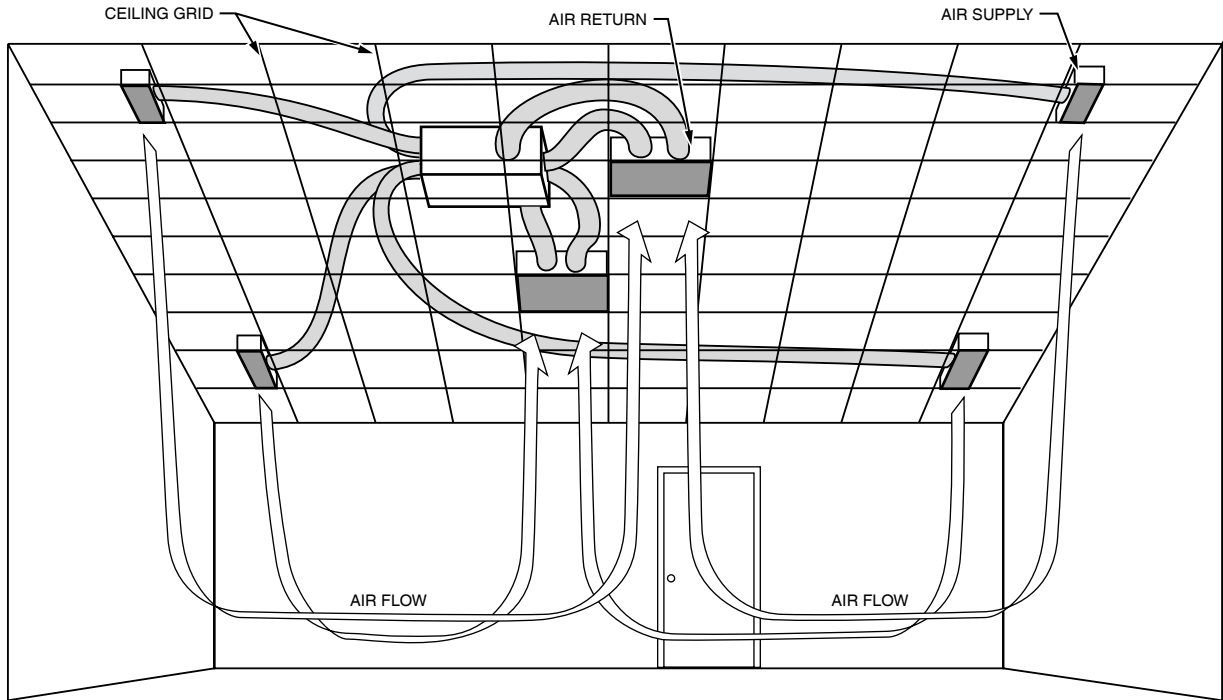

M13407

Fig. 2. Mounting F120.

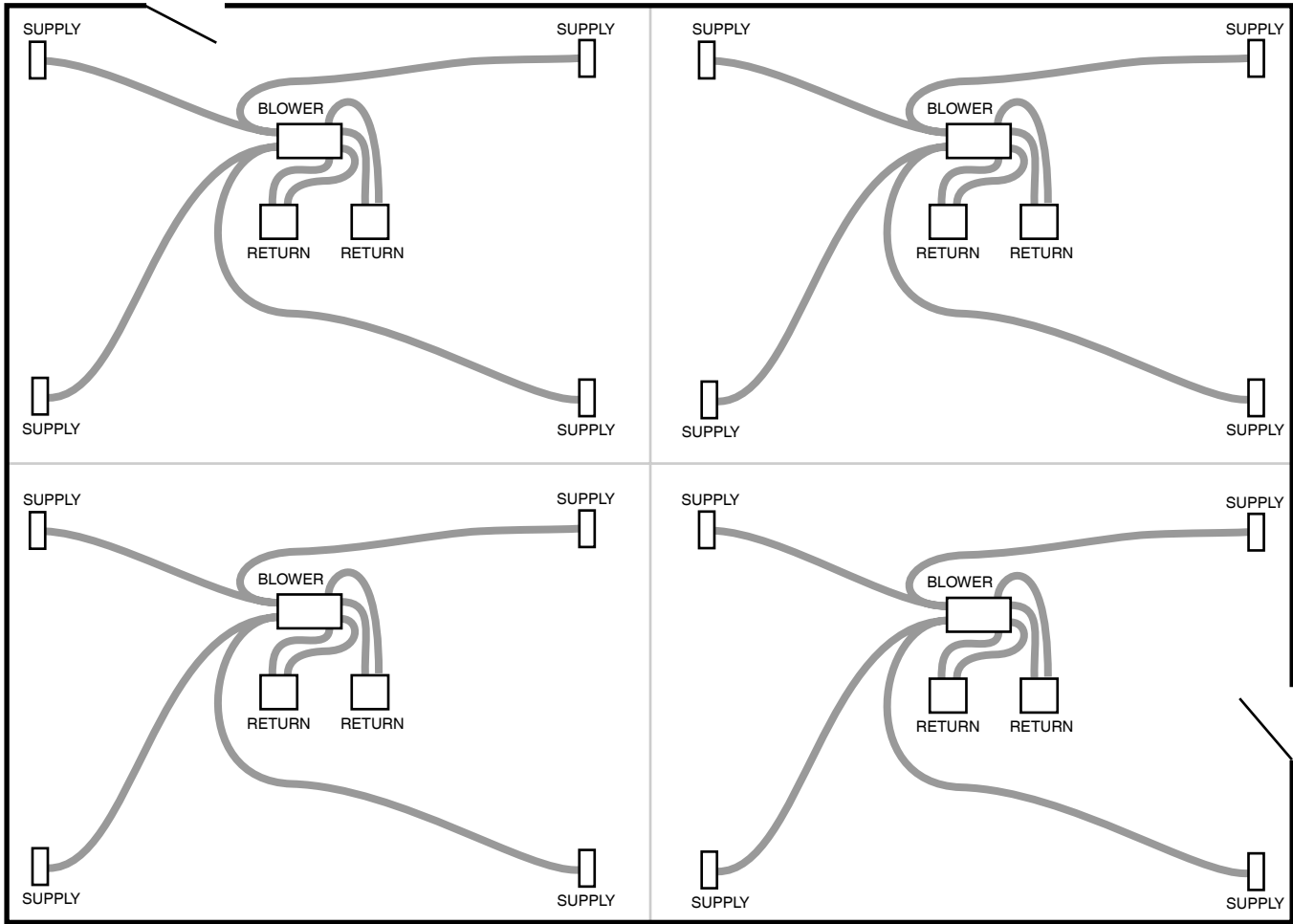

M13408

Fig. 3. Installing multiple F120.

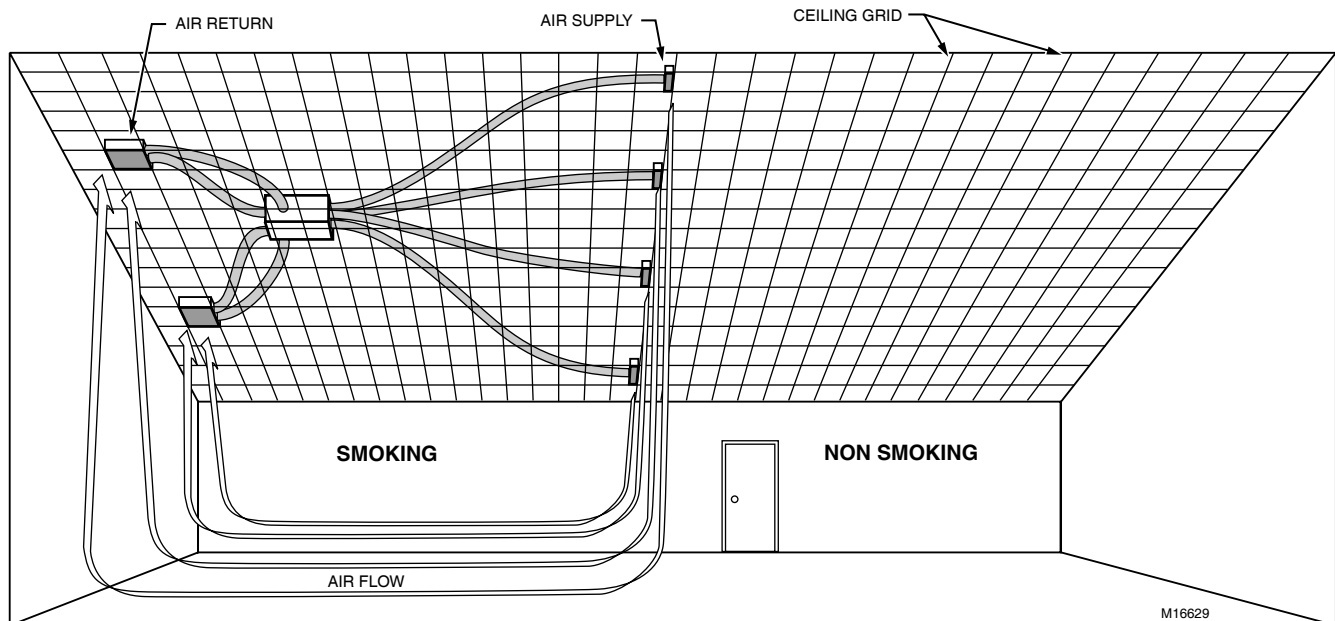

M16629

Fig. 4. Dividing a large area into smoking and non-smoking sections.

2. Examine the space above the drop ceiling for obstructions, such as piping for sprinkler systems, HVAC ducting or electrical wiring for the lighting system, that can interfere with installing the F120.
3. Decide where to mount the F120 modules:
 - a. Hang the blower module from the structural ceiling above the drop ceiling (minimum of 17 in. is required).
 - b. Allow a minimum of 16 in. clearance on all four sides for the flexible ductwork.
 - c. For the return and supply modules, allow a minimum of 12 in. clearance between the drop ceiling and the structural ceilings, with clearance on one side for duct access.
4. If the exhaust feature is used with the F120, determine the location of the exhaust discharge. If the discharge is more than 50 ft. from the blower module, use an optional booster blower to achieve adequate exhaust airflow.
5. For optimum performance of each F120 System:
 - a. Use the sizing formulas to determine the number of F120 required for the larger room.
 - b. Visually divide the entire room into several cubic volumes. For example, if three F120 are planned, visualize the room as three roughly equal cubic volumes.
 - c. Consider each cubic volume as a single room, and install the return modules at the center of each area with the supply modules on the periphery.
 - d. Draw an installation layout diagram showing the location of the blower, return and supply modules, and the exhaust outlet (optional). Use this diagram later during the air cleaning system installation.

3. The installer must be a trained, experienced service technician.
4. After installation is complete, check out product operation as provided in these instructions.

Unpacking Air Cleaning System



CAUTION

Personal Injury Hazard.

Sharp metal edges on components of air cleaning system can injure hands and fingers.

Wear protective gloves and carefully handle system components to avoid cuts from sharp metal edges.

Preparing Air Cleaning System for Installation

1. Unpack, identify and inventory all parts:
 - Literature.
 - Mounting hardware kit: 12 mounting brackets, 40 ft (12m) of 12-gauge high tensile strength wire, duct tape, six 2-ft (0.6) drop-ceiling T-bar mounts.
 - Two return modules with grilles.
 - Four supply modules with grilles.
 - Two high-efficiency filters — either HEPA or DOP and CPZ module.
 - One package (12) prefilters.
 - Blower module.
 - Seven duct-collar straps.
 - Duct tape.
2. Remove the grilles from the return and supply modules and set aside until the modules are mounted in the drop ceiling.
4. Remove all shipping cardboard, plastic and containers from the system parts.
5. Locate additional items required for the installation (not included) that the installer provides:
 - a. External hardware such as extra nuts and bolts secure the mounting wire or chain to the ceiling.
 - b. Leveling tool.
 - c. Drop-ceiling T-bars (4) two-feet (0.6m) long if grids supplied do not match the grid system.

INSTALLATION



WARNING

Explosion Hazard.

Can cause personal injury or equipment damage. Do not install or use the F120 Room Air Cleaning System where there is any danger of gas, vapor or dust explosion.

Do not install when explosion-proof electrical fixtures are specified.

Canadian Installation: Do not use in ceilings where fire-resistant assemblies are specified.



WARNING

Fire or Electric Shock Hazard.

Can cause personal injury or equipment damage. Turn off power source before installing or servicing the air cleaning system.

When Installing this Product...

1. Read these instructions carefully. Failure to follow them could damage the product or cause a hazardous condition.
2. Check the ratings given in the instructions and on the product to make sure the product is suitable for your application.

Preparing Area for Installation

1. Refer to the installation diagram for locations of the blower, return and supply modules and remove ceiling panels from those locations.
2. Verify the required clearance between the drop and structural ceilings:
 - blower module clearance of 17 in. (430 mm); 16 in. (400 mm) clearance is required on all four sides for ductwork.
 - return module clearance of 12 in. (304 mm).
 - supply module clearance of 10 in. (205 mm).
 - clearance for ductwork.
 - 6 in. (150 mm) diameter between blower and supply modules.

- 8 in. (200 mm) diameter between blower and return modules.
- clearance for exhaust duct.

Installing Blower Module

1. Prepare blower module to mount entirely above the drop ceiling.
2. Mark the location for the mounting bolts in the structural ceiling. See Fig. 5.
3. Install the mounting bolts in the structural ceiling.

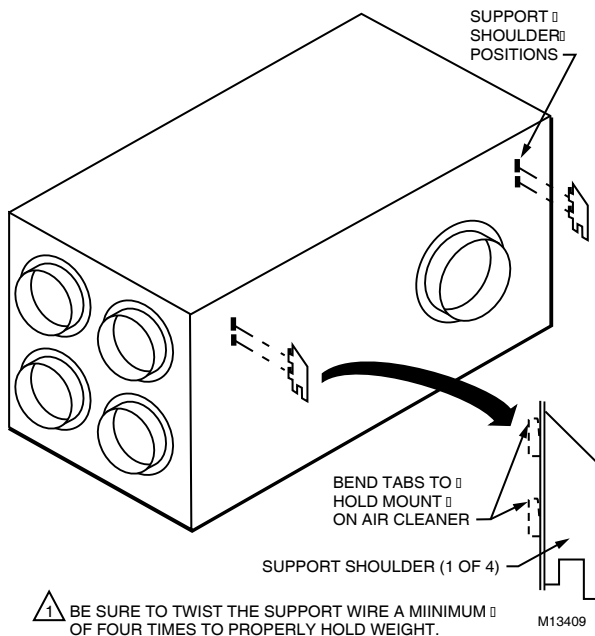
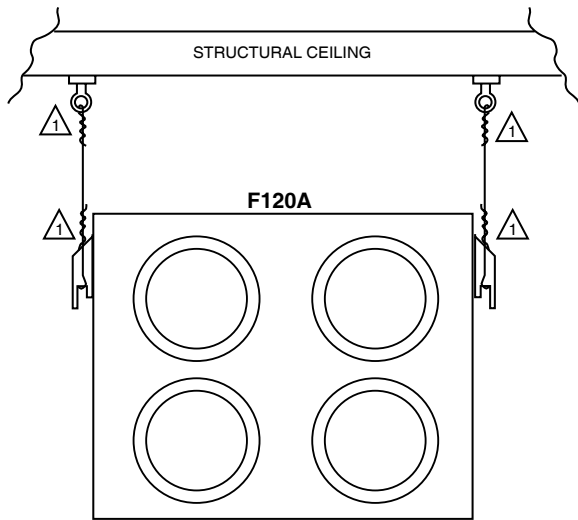

Fig. 5. Installing blower module mounting bolts.

WARNING

Fire and Electric Shock Hazard.

Can cause personal injury or equipment damage.

Wait to connect the power source to the blower module after securely mounting in the ceiling.

4. Locate the multiple slots on the blower module for mounting the support shoulder mounting brackets. See Fig. 5.
5. Insert the brackets into the selected slots.
6. Thread the wire through the brackets. Do not rest the blower module on the T-bar unless it is reinforced to hold the weight.
7. Twist the support wire a minimum of four times.

CAUTION

Personal Injury or Equipment Damage Hazard.

Equipment can fall and injure installer or become structurally weakened, buckled or damaged.

Verify platform is stable and can bear combined weight of installer and equipment.

Seek installation assistance to prevent return module from accidentally falling or dropping.

8. Standing on a secure platform, lift the module and raise it up above the drop ceiling.
9. Attach the free ends of the support wires to the bolts mounted in the structural ceiling.
10. Check the wire to observe that it supports the blower module.
11. Level the blower module.

Installing Return Module

1. The return module mounts level with the drop ceiling T-bars. Mark the location for the mounting bolts in the structural ceiling. See Fig. 6.
2. Install the mounting bolts in the structural ceiling.
3. Locate the return module slots for mounting the shoulder support mounting brackets.
4. Insert the brackets into the selected slots.
5. Orient the return module so the duct collars are pointing correctly.
6. Thread the wire through the support shoulders. Do not rest the blower module on the T-bar unless it is reinforced to hold the weight.
7. Twist the support wire a minimum of four times.

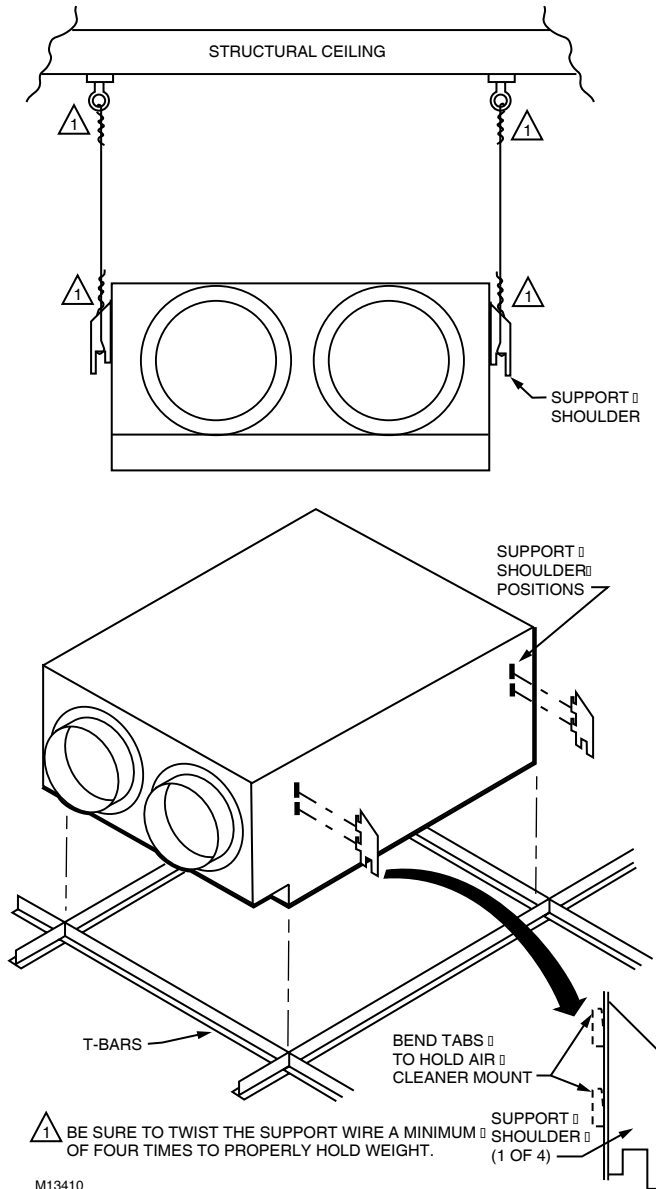

Fig. 6. Installing return module.

⚠ WARNING

Personal Injury or Equipment Damage Hazard. Equipment can fall and injure installer or become structurally weakened, buckled or damaged. Verify platform is stable and can bear combined weight of installer and equipment. Seek installation assistance to prevent return module from accidentally falling or dropping.

8. Standing on a secure platform, lift the module and insert it into the drop ceiling opening level with the T-bars.
9. Attach the free end of the support wire to the bolts mounted in the structural ceiling.
10. Level the return module.

NOTE: If installed in a 2 x 4-foot ceiling grid, use the two-foot T-bar provided to trim the return grille. Resize the drop ceiling panel, if necessary, to fit.

Installing Supply Module

The supply modules are mounted directly on the drop-ceiling T-bars. Orient the modules so the duct collars are pointing correctly for easy duct attachment. See Fig. 7

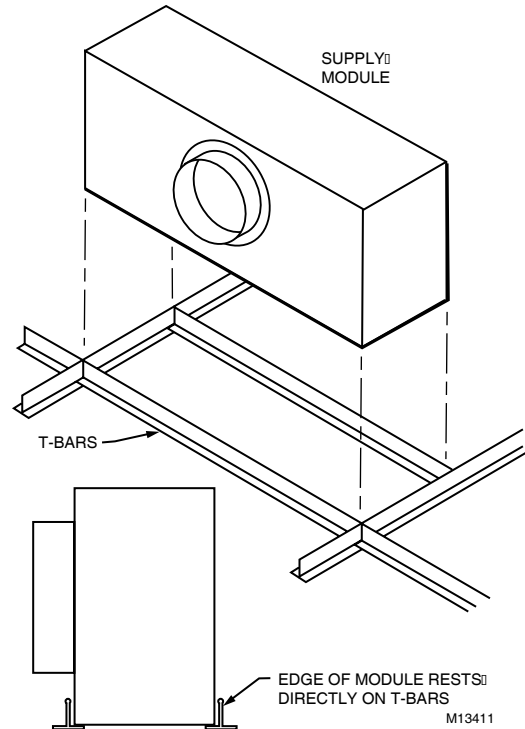

Fig. 7. Mounting supply modules.

1. Mount the modules directly on the drop ceiling T-bar.
2. Install the two-foot T-bar.
3. Resize the drop ceiling panel to fit.
4. Install the grille by inserting it into the supply module and letting it rest on the T-bar.

Installing System Ductwork

Select models of the F120 System include 75 feet of 6 in. diameter flexible ducting to connect the four supply modules to the blower module. It also includes 75 feet of 8 in. diameter flexible ducting to connect the two return modules to the blower module.

1. Measure the 6 in. diameter duct lengths (distance between blower and supply module 6 in. diameter collars).
2. Cut the ducting to the correct lengths.
3. Install the 6 in. ducting between the blower and the supply modules.
4. Use duct tape and straps to secure the flexible ducting to the collars.
5. Measure the 8 in. diameter ducting lengths (distance between blower and return module 8 in. diameter collars).

6. Cut the ducting to the proper lengths (two 8 in. diameter ducting are required for each return module).
7. Install the 8 in. ducting to the blower module and to the return modules.
8. Use duct tape and straps to secure the flexible ducting to the collars.
9. If using the F120 room exhaust feature, measure the length from the blower exhaust to the exhaust outlet.
10. Attach the exhaust ducting to the blower exhaust using duct tape and straps.

Wiring

The F120 has a standard 2 x 4 in. (50 x 100 mm) electrical box for field wiring. The field-wiring compartment is located on the return end of the blower module.

IMPORTANT

All wiring must comply with applicable codes and ordinances. Check that the air cleaner is grounded for proper operation and safety.

Canadian installation: Do not install in ceilings with thermal insulation value greater than R-40.

1. Use the appropriate knockout to run the electrical wiring into the box.
2. Connect the electrical wiring as shown in the Fig. 8.

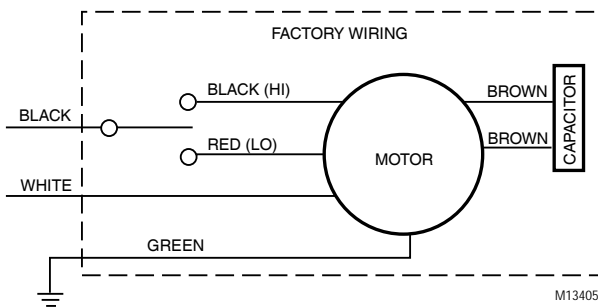

Fig. 8. F120 wiring diagram.

WARNING

Electric Shock Hazard.

Can cause personal injury or equipment damage.

Be extremely careful to avoid electrical shock during operation checkout.

Be extremely careful when working near moving parts.

Installing Filters

The F120 offers two types of filters:

1. 99% HEPA.
2. 95 percent DOP with CPZ module.

All filters are installed the same. See Fig. 9.

IMPORTANT

Wear safety goggles when installing or removing the overhead CPZ™ modules to avoid contact with dust released during normal handling.

CAUTION

Equipment Damage Hazard.

Can damage filter frame or filter media.

Avoid touching pleated filter media.

Handle only the filter frame.

1. Remove filters from plastic wrapper.
2. Be sure front of filter assembly rests on filter support hooks in return module.
3. Make sure airflow direction arrow is pointing toward top of return module and the filter eye hook faces out.
4. Carefully lift the filter and hook frame onto the support hooks.
5. Swing the filter into the unit and latch the filter frame securely to the module by inserting the module hook through the eye bolt on the filter.

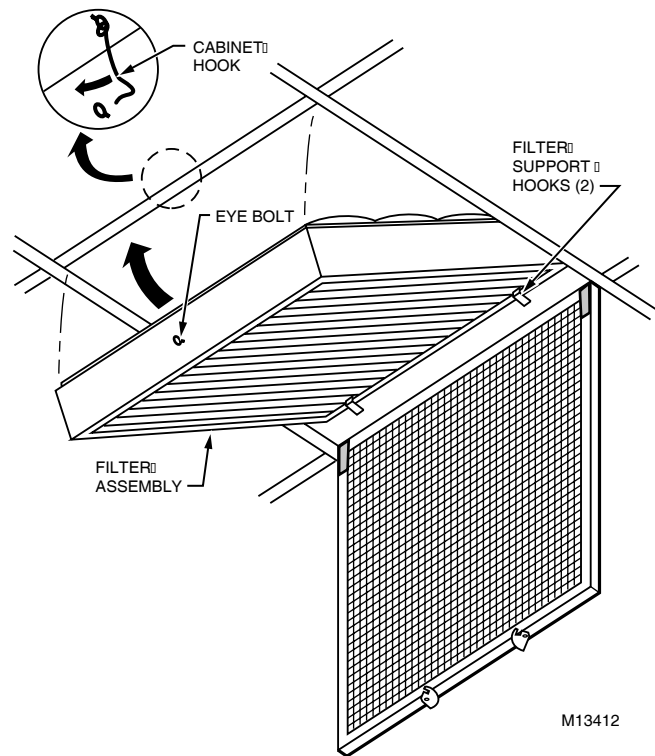

Fig. 9. Installing F120 filters.

Installing Grille and Prefilter

When installing, allow space for pulling down the grille a radius of two feet to open it. Be sure it can open freely without obstruction.

1. Install the grille by inserting the grille hinge hooks into the opening in the return module. Be sure the grille hangs freely from the cabinet. See Fig. 10.
2. Install the prefilter by pressing the filter onto the velcro-fasteners at the top of the hanging grille. See Fig. 10.
3. Swing the grille up into the cabinet and rotate the two latches closed.

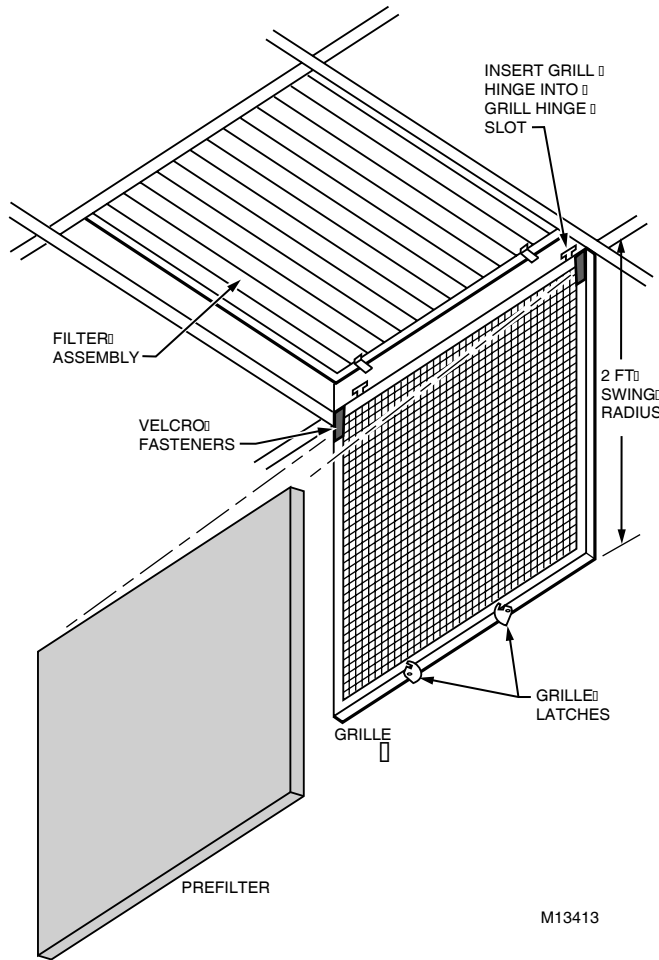

Fig. 10. Installing grille and prefilter.

OPERATION

The F120 System is engineered to improve indoor air quality for commercial applications. The filters effectively capture atmospheric dust, mold spores, smoke, fumes, mists and aerosols.

Air cleaning systems and ventilators use filtration or dilution to reduce excessive accumulation of contaminants. To eliminate airborne contaminants, the source must be removed.

Ventilation standards and codes specify minimum ventilation rates to dilute air contamination for specific applications. The rates assume a fresh outdoor air exchange.

Using the F120 to comply with ventilation requirements is an acceptable alternative to ventilation with outdoor air. It is recommended that a minimum of 15 cfm per person outdoor air be provided.

MAINTENANCE

The F120 Room Air Cleaning System is designed with a dual filter to allow longer intervals between maintenance. Regular maintenance of the prefilter and filter assembly can be done easily without special tools:

1. Remove and replace the HEPA filter, which collects smaller particles not collected by the prefilter. (Washing, vacuuming and reverse air blasting the filter are not effective.) The filter lasts 12 to 24 months, depending on facility occupancy factors.
2. Change the disposable prefilter after every one to two months of operation.
3. Replace the CPZ Module every four to 24 months, depending on the application, when the adsorbent emits a continuously strong pungent odor.

NOTE: When tobacco smoke is the contaminant, replace both the 95 percent DOP filter and the CPZ module at the same time.

Replacing the filter

1. Open the two grille latches by swinging down the grille.
2. Remove the dirty prefilter from the velcro holders.
3. Unhook the filter assembly and swing it out of the unit.
4. Lift the filter assembly from the installation hooks and place it on the floor.
5. Install the filter assembly by positioning it on the installation hooks with the air flow arrows pointing up to the unit.
6. Replace the prefilter pad by attaching it to the velcro holders.
7. Swing the grille into the unit and close the latches.

PARTS LIST

See Fig. 11 for exploded view of F120.

Item No.	F120A Part No.	Description
1	32003982-001	Return Module (without filters)
2	32003983-001	Prefilter (12 pack)
3	32003984-001	Return Grille Assembly
4	32003985-001	95% DOP Filter
5	32003986-001	99.97% HEPA Filter
6	32003987-001	CPZ Module
7	32003988-001	CPZ Module Frame
8	32003989-001	Blower
9	32003990-001	Motor
10	32003991-001	Blower Module
11	32003992-001	Supply Module with Grille
12	32003993-001	Supply Grille
13		
14		
15	32003995-001	Motor Capacitor
Parts Not Shown in Fig.11.		
	32003996-001	Exhaust Kit F120 Upgrade
	32003997-001	Filter Exchange Pack
	32004137-001	High, Off, Low Switch
	32004138-001	Mounting Hardware Kit

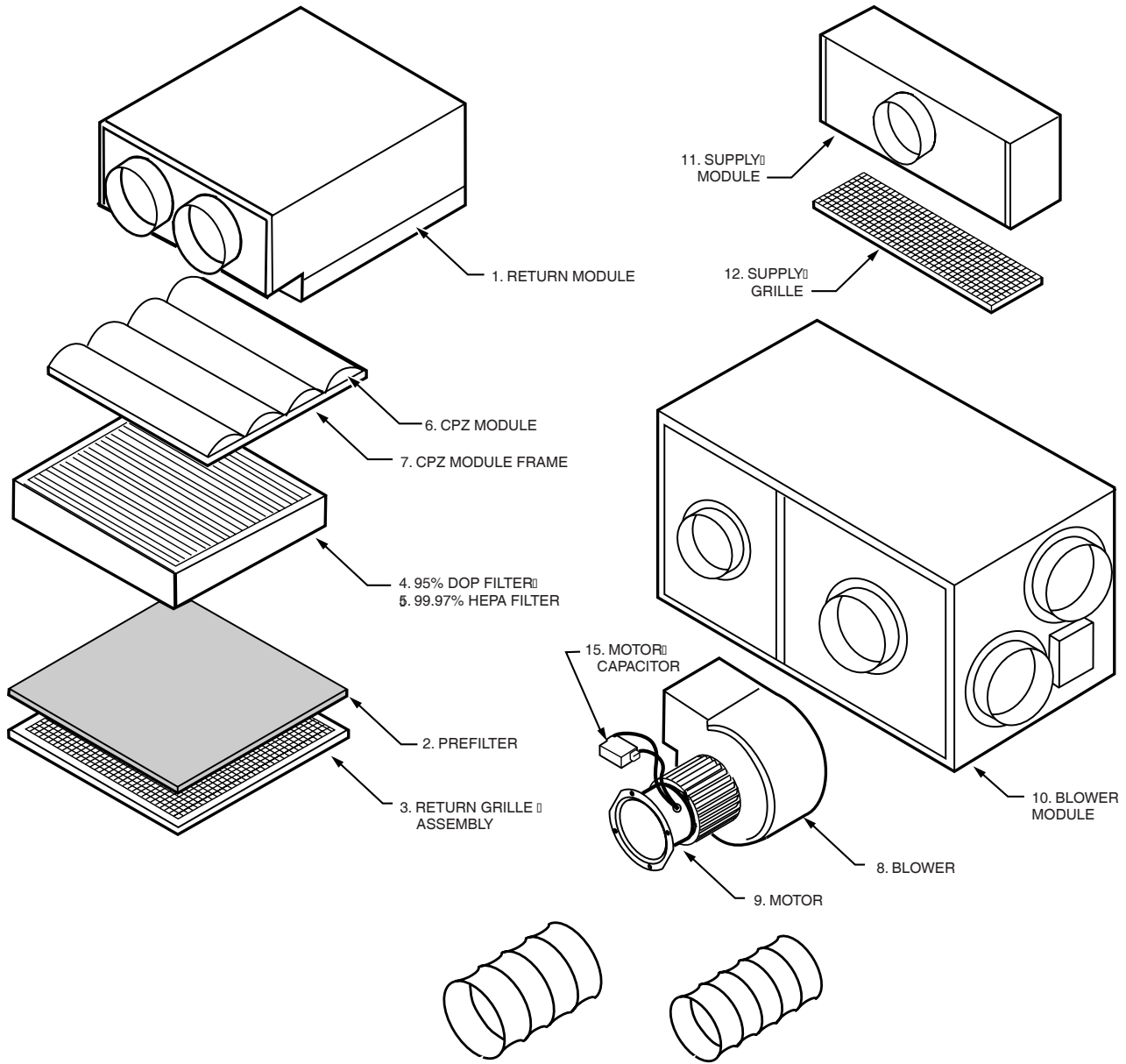

M13414

Fig. 11. F120 exploded view.

NOTES

NOTES

NOTES

LIMITED TWO-YEAR WARRANTY

Air-Pure Systems warrants its air cleaner products to be free from defects in workmanship or materials under normal use and service, for a period of two (2) years from the date of purchase by the original end-user. If at anytime during the warranty period the product is defective or malfunctions, Air-Pure Systems, through the distributor or dealer, from which the product was purchased, or through an authorized warranty repair station, shall at Air-Pure Systems option, replace or repair the defective product or component.

This warranty does not cover removal or installation costs. This warranty shall not apply if it is shown that the defect or malfunction was caused by damage which occurred during handling or shipment, improper electrical connections, improper use of the product or abuse.

Air-Pure Systems sole responsibility shall be to repair or replace the product within the terms stated above. **AIR-PURE SYSTEMS SHALL NOT BE LIABLE FOR ANY LOSS OR DAMAGE OF ANY KIND, INCLUDING ANY INCIDENTAL OR CONSEQUENTIAL DAMAGES RESULTING, DIRECTLY OR INDIRECTLY, FROM ANY BREACH OF WARRANTY, EXPRESS OR IMPLIED, OR ANY OTHER FAILURE OF THIS PRODUCT.** (Some states do not allow the exclusion or limitation of incidental or consequential damages, so this limitation may not apply to you.) **THE WARRANTIES SET FORTH HEREIN ARE EXCLUSIVE AND AIR-PURE SYSTEMS EXPRESSLY DISCLAIMS ALL OTHER WARRANTIES, WHETHER WRITTEN OR ORAL, IMPLIED OR STATUTORY, INCLUDING BUT NOT LIMITED TO ANY WARRANTIES OF MERCHANTABILITY, WORKMANSHIP, OR FITNESS FOR A PARTICULAR USE.**

This warranty gives you specific legal rights and you may have other rights which vary from state to state.

How to make a warranty claim or have questions answered:

Should you have a warranty claim or questions about the warranty policy, contact the distributor or dealer from which you purchased the product or the authorized warranty repair stations nearest your location.

NOTE: Do not return any products or parts to the factory without a factory issued "Returned Warranty Goods Label" issued by Air-Pure Systems.

In the event you or other persons, have any questions concerning the use and care of this product or this warranty please call or write the factory.

Air-Pure Systems
16873 Fish Point Rd. SE
Prior Lake, MN 55372-1714
Phone: (800) 998-1919
Fax: (800) 221-3248

Air-Pure Systems
16873 Fish Point Rd. SE
Prior Lake, MN 55372-1714
Phone: (800) 998-1919
Fax: (800) 221-3248